

Application & General Notes:

These installation instructions apply to Fire Dampers of the static, dynamic, curtain-style, single and multi-blade types mounted in the plane of a UL* approved fire partition. For dampers needed to be installed outside the plane of a UL approved wall or floor, refer to the Out of Wall Fire and Fire/Smoke Damper IOM. The dampers are designed for operation in the vertical or horizontal orientation with blades running horizontal.

Safety Warning:

Read all installation, operating and maintenance instructions thoroughly before installing or servicing this equipment. Improper installation, adjustment, alteration, service or maintenance can cause property damage, injury or death.

Receiving & Handling:

Check for damage when this product is received. If damage is found, record all necessary information on the bill of lading and file a claim with the final carrier. Check to be sure that all parts of the shipment are accounted for.



UL/ULC File: R27700

The following installation instructions are UL approved to be used with the following CVS Models: FD, FD-SL, FD-USL, FD-MB-3V, FD-MB-AF, FDD, FDD-SL, FDD-MB-3V, and FDD-MB-AF.

Installation Supplements:

- Installing Fire and Combination Fire/Smoke Dampers in a Shaft Wall
- Framing Requirements for Wood or Steel Stud Walls
- UL Approved Breakaway Duct Connections
- Optional Sealing of Dampers in Fire and Smoke Rated Walls or Floors
- Fabrication and Installation of Support Mullions
- Field Modification of Factory Supplied Sleeves
- Installing Fire and Fire/Smoke Dampers in Concrete Floor with Steel Deck

Other Installation References:

- Out-of-Wall Fire, Smoke and Fire/Smoke Damper IOM
- True Round Fire, Smoke and Fire/Smoke Damper IOM

Electrical Guidelines:

Electrical input may be needed for products discussed within this IOM. All wiring shall be done in accordance with the latest edition of the National Electrical Code ANSI/NFPA-70, any local codes that may apply and wiring diagrams developed in compliance with the job or project design and specifications.

Electrical input work should be performed by a qualified electrician. Verify power before wiring actuator. CVS is not responsible for damage to or failure of the unit caused by incorrect field wiring.

Follow all instructions carefully.

*When UL is referred to in this document, it represents UL/ULC (Underwriter's Laboratories of United States and Canada).

This IOM manual is the property of the owners, and is required for future maintenance. Please leave it with the owner when the job is complete.

TABLE OF CONTENTS

Pre-Installation Guidelines	2
Max. Size Tables for CVS Fire Dampers	2
Damper Sleeves & Multiple Sections	3
Damper Transitions	3
2 Angle Method Installation	4
1 Angle Method Installation	5
No Angle Method Installation	6
Fire Damper Operation, Testing & Maintenance	7

Pre-Installation Notes & Guidelines:

These notes and guidelines are formulated in order to aid in completing the damper installation in a timely and efficient manner.

- A. Inspect damper for damage before installing
- B. Dampers must be installed free from twisting or racking
- C. DO NOT compress or stretch the damper into the opening
- D. DO NOT lift the damper by the blades or actuator (handle damper using frame or sleeve)
- E. The damper must be protected from dirt, dust and foreign materials before and after installation
- F. When painting, wall-texturing, insulating or any other foreign material is being sprayed within 5 feet of the damper, the damper must be sufficiently covered and protected
- G. Suitable access inside the duct and to the damper must be created for inspection and service of the damper per NFPA 90A and local authority having jurisdiction

Table 1: Maximum Size Fire Dampers

	MODEL	VERTICAL				HORIZONTAL			
		SINGLE SECTION		MULTI-SECTION		SINGLE SECTION		MULTI-SECTION	
		1.5 HOUR	3 HOUR	1.5 HOUR	3 HOUR	1.5 HOUR	3 HOUR	1.5 HOUR	3 HOUR
S T A T I C	FD	60x60 (1524x1524)	48x48 (1219x1219)	120x120 (3048x3048)	80x40 (2032x1016)	48x48 (1219x1219)	40x40 (1016x1016)	120x40 or 96x48	80x40 (2032x1016)
	FD-SL	60x60 (1524x1524)	48x48 (1219x1219)	120x120 (3048x3048)	80x40 (2032x1016)	48x48 (1219x1219)	40x40 (1016x1016)	120x40 or 96x48	80x40 (2032x1016)
	FD-MB-3V	36x48 (914x1219)	36x48 (914x1219)	108x96 (2743x2438)	72x48 (1828x1219)	36x48 (914x1219)	36x48 (914x1219)	72x48 (1828x1219)	72x48 (1828x1219)
	FD-MB-AF	36x48 (914x1219)	36x48 (914x1219)	108x96 (2743x2438)	72x48 (1828x1219)	36x48 (914x1219)	36x48 (914x1219)	N/A	N/A
	FD-USL ¹	48x48 (1219x1219)	48x48 (1219x1219)	80x40 (2032x1016)	80x40 (2032x1016)	N/A	N/A	N/A	N/A
D Y N A M I C	FDD	36x36 (914x914)	36x36 (914x914)	72x36 or 36x72 (1219x1828)	72x36 or 36x72 (1219x1828)	24x24 (610x610)	24x24 (610x610)	36x36 (914x914)	36x36 (914x914)
	FDD-SL	24x24 (610x610)	24x24 (610x610)	36x36 (914x914)	36x36 (914x914)	24x24 (610x610)	24x24 (610x610)	36x36 (914x914)	36x36 (914x914)
	FDD-MB-3V	36x48 (914x1219)	36x48 (914x1219)	108x96 ² (2743x2438)	72x96 ² (1828x2438)	36x48 (914x1219)	36x48 (914x1219)	72x96 ² (1828x2438)	72x96 ² (1828x2438)
	FDD-MB-AF	36x48 (914x1219)	36x48 (914x1219)	108x96 ² (2743x2438)	72x96 ² (1828x2438)	36x48 (914x1219)	36x48 (914x1219)	N/A	72x96 ² (1828x2438)

¹The FD-USL is an Ultra Slim Line Model and only available in the vertical orientation.

²These sizes may require the use of an actuator (see applicable wiring diagrams).

(All dimensions in parentheses () are in millimeters).

FIRE DAMPER SLEEVES & MULTIPLE SECTIONS

Damper Sleeves:

All fire dampers must be installed in a sleeve. Sleeves may be integral to the damper, fabricated in the field or included with the damper from the factory. Integral sleeve dampers must use UL approved breakaway connections (see separate UL Approved Breakaway Duct Connections IIS).

Guidelines:

- A.** Sleeves must be of the SAME GAUGE or heavier than the duct to which it is attached if one of the UL approved breakaway connections is used (see separate UL Approved Breakaway Duct Connections IIS).
- B.** Gauges shall conform to SMACNA or ASHRAE duct standards.
- C.** Sleeves shall not extend beyond the fire barrier more than 6" (152mm) unless an actuator or factory installed access door is supplied, then the sleeve may extend up to 16" (406mm) (see Figure 1).
- D.** The sleeve shall terminate at both sides of the wall or floor while remaining within the above parameters (see Figure 1).
- E.** If a rigid connection is used then the sleeve shall be a minimum of 16 gauge (1.6mm) for dampers up to 36" (914mm) wide by 24" (610mm) high and 14 gauge (2mm) for dampers exceeding either of those dimensions.

Multiple Section & Damper-to-Sleeve Connections:

The damper shall be secured to a sleeve and/or to each other (when joined to make multiple section damper assemblies) in the following manner:

- A.** Using any of the following approved fasteners:
 1. #10 sheet metal screws
 2. ¼" (6mm) nut and bolts
 3. ¼" (6mm) tack welds
 4. 3/16" (5mm) steel rivets
 5. Clinching (toggle) locks
- B.** All above approved fasteners shall be spaced on 6" (152mm) centers and a maximum of 2" (51mm) from corners (see Figure 1).
- C.** The above approved fasteners shall be on both sides (faces) of the damper (see Figure 1).

Damper Transitions:

CVS offers several transitions to accommodate the need for duct type specific joining as well as for better free area and lower pressure drop through the damper. The transitions are square/rectangular-to-square/rectangular, square/rectangular-to-round and square/rectangular-to-oval. The different types of curtain-style fire dampers are as follows: Type A (blades and frame in airstream), Type B (frame in airstream) and Type C (no blades or frame in airstream - 100% free area) (see Figure 2).

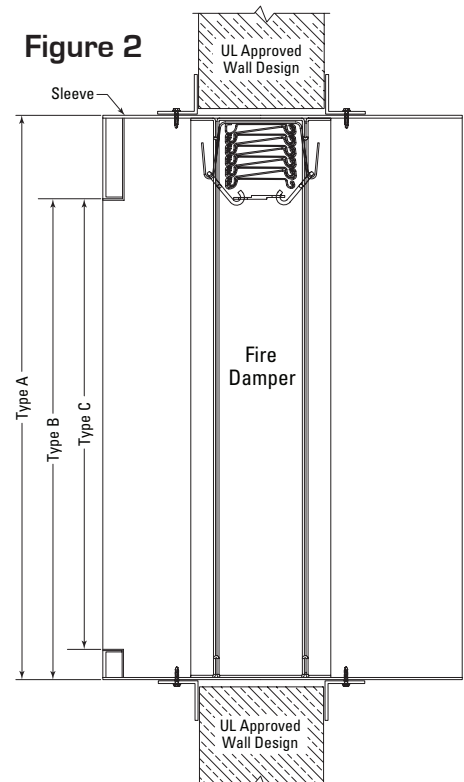
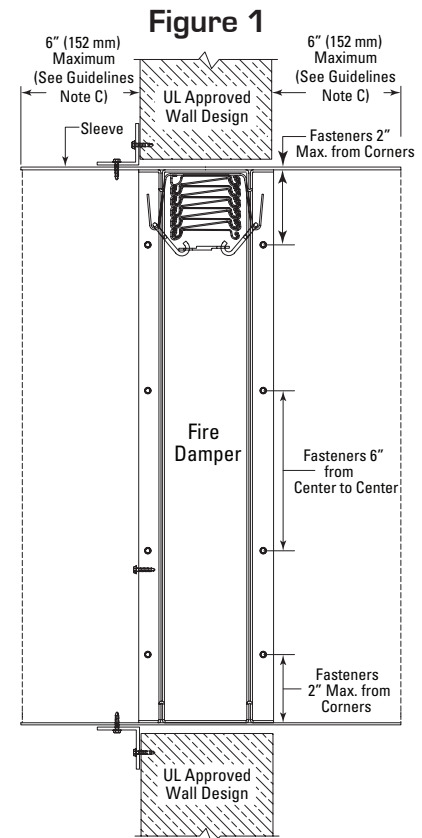

2 ANGLE (2 SIDED) INSTALLATION METHOD

Opening/Clearances:

The fire barrier opening shall be larger than the damper in order to allow for thermal expansion and ease of installation (see Figure 3:A-E). The damper does not have to be centered in the wall or floor, only the blade closure line must be within the wall or floor (see Figure 3:A-B). The opening in the fire-rated partition using the 2 angle method shall be 1/8" (3mm) per linear foot (305mm) of height and width of the sleeved assembly larger, up to a maximum of 1 1/2" (38mm) and a minimum of 1/4" (6mm). Recommended clearances:

- A. 48" (1219mm) or less: 1/2" (13mm) clearance
- B. More than 48" (1219mm) and 96" (2438mm) and less: 1" (25mm) clearance
- C. More than 96" (2438mm): 1 1/2" (38mm) clearance

Important Note: The clearances mentioned above are for the total clearance for the damper and does not necessarily need to be met on every side of the damper.

No materials (i.e. Fire Stop, Mineral Wool, etc.) are to be placed in this clearance between the damper sleeve and the wall/floor opening.

Guidelines:

The Two Angle Method (Figure 3:A-E) is approved for the following:

- A. Masonry/concrete walls or floors and stud/gypsum walls
- B. 1 1/2 and 3 Hour rated dampers
- C. Vertical (see Figure 3-A) or horizontal (see Figure 3-B) orientation
- D. Maximum and minimum UL approved damper sizes that are listed in Table 1 on page 2 of this IOM

Installation:

- A. Angles shall be CVS's Framed Retaining Angles (model FRA) OR a minimum of 1 1/2" x 1 1/2" (38mm x 38mm) and minimum of 16 gauge (see Figure 3:D-E).
- B. Use any of the following approved fasteners:
 - 1. #10 sheet metal screws
 - 2. 1/4" (6mm) nut and bolts
 - 3. 1/4" (6mm) tack welds
 - 4. 3/16" (5mm) steel rivets
 - 5. Clinching (toggle) locks
- C. Angles are to be fastened to the sleeve only, on 6" centers using the above approved fasteners with no more than 2" (51mm) from each end and two connections minimum per side/leg (see Figure 3-C).
- D. Angles are to overlap the partition a minimum of 1" (25mm) (see Figure 3:D-E).
- E. When the duct work terminates at the damper or installation prohibits the angles from turning out/away from the partition, angles may be reversed and turned inward as in Figure 3-E (leg turned into the opening) while maintaining proper expansion clearances (refer to the above section "Opening/Clearances").

Figure 3: 2 Angle Installation

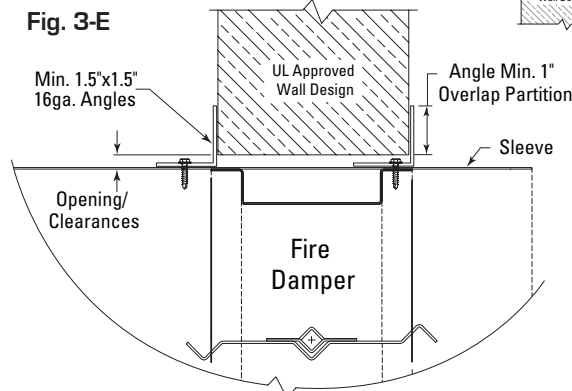
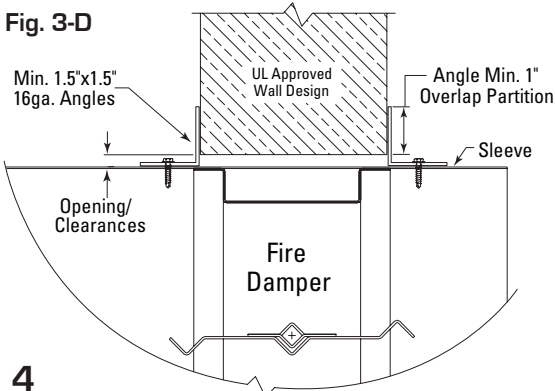
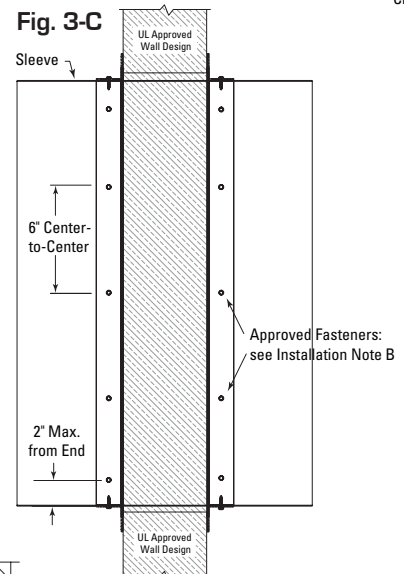
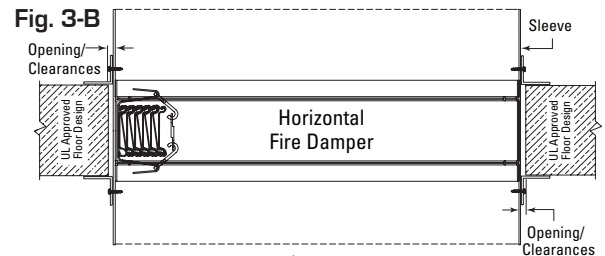
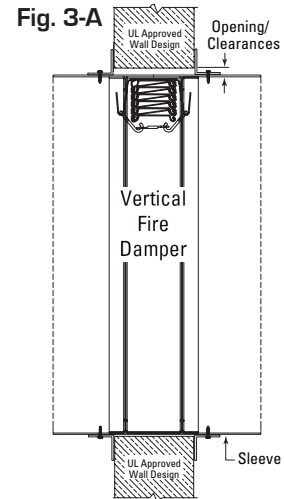

1 ANGLE (1 SIDED) INSTALLATION METHOD

Opening/Clearances:

The fire barrier opening shall be larger than the damper in order to allow for thermal expansion and ease of installation (see Figure 4:A-F). The damper does not have to be centered in wall or floor, only the blade closure line must be within the partition (see Figure 4:A-B). The opening in the fire rated partition using the 1 angle method shall be 1/8" (3mm) per linear foot (305mm) of height and width of the sleeved assembly larger, up to a maximum of 1/2" (38mm) and a minimum of 1/4" (6mm). Recommended clearances:

- A. 48" (1219mm) or less: 1/2" (13mm) clearance
- B. More than 48" (1219mm) and 96" (2438mm) and less: 1" (25mm) clearance
- C. More than 96" (2438mm): 1 1/2" (38mm) clearance

Important Note: The clearances mentioned above are for the total clearance for the damper and does not necessarily need to be met on every side of the damper.

No materials (i.e. Fire Stop, Mineral Wool, etc.) are to be placed in this clearance between the damper sleeve and the wall/floor opening.

Guidelines:

The One Angle Method (Figure 4:A-F) is approved for the following:

- A. Masonry/concrete walls or floors and stud/gypsum walls
- B. 1 1/2 Hour rated dampers
- C. Vertical (see Figure 4-A) or horizontal (see Figure 4-B) (angles on top side only) orientation
- D. The maximum sizes allowed for this method is 108" (2743mm) wide or 108" (2743mm) high up to 36 square feet

Installation:

- A. Angles shall be CVS's Framed Retaining Angles (model FRA) OR a minimum of 1 1/2" x 1 1/2" (38mm x 38mm) and minimum of 16 gauge (see Figure 4:C-D).
- B. Use any of the following approved fasteners:
 - 1. #10 sheet metal screws
 - 2. 1/4" (6mm) nut and bolts
 - 3. 1/4" (6mm) tack welds
 - 4. 3/16" (5mm) steel rivets
 - 5. Clinching (toggle) locks
- C. Angles are to be fastened to the sleeve on 6" (152mm) centers using the above approved fasteners with no more than 2" (51mm) from each end and two connections minimum per side/leg (see Figure 4-E).
- D. Angles are to overlap the partition a minimum of 1" (25mm) (see Figure 4-C) and also be fastened to the partition using #10 (M5) self-tapping concrete anchors or concrete screws engaging the fire partition a minimum of 1 1/2" (38mm) for masonry/concrete partitions or #10 (M5) screws long enough to penetrate the J-Runners and E-Stud by a minimum of 3/8" (10mm) for stud/gypsum partitions.
- E. In a steel stud application, the angle may be placed in front of or behind the drywall attaching directly to the metal studs (see Figure 4:C-D).
- F. When the duct work terminates at the damper or installation prohibits the angles from turning out/away from the partition, angles may be reversed and turned inward as in Figure 4-F (leg turned into the opening) while maintaining proper expansion clearances (refer to above section "Opening/Clearances").

Figure 4: 1 Angle Installation

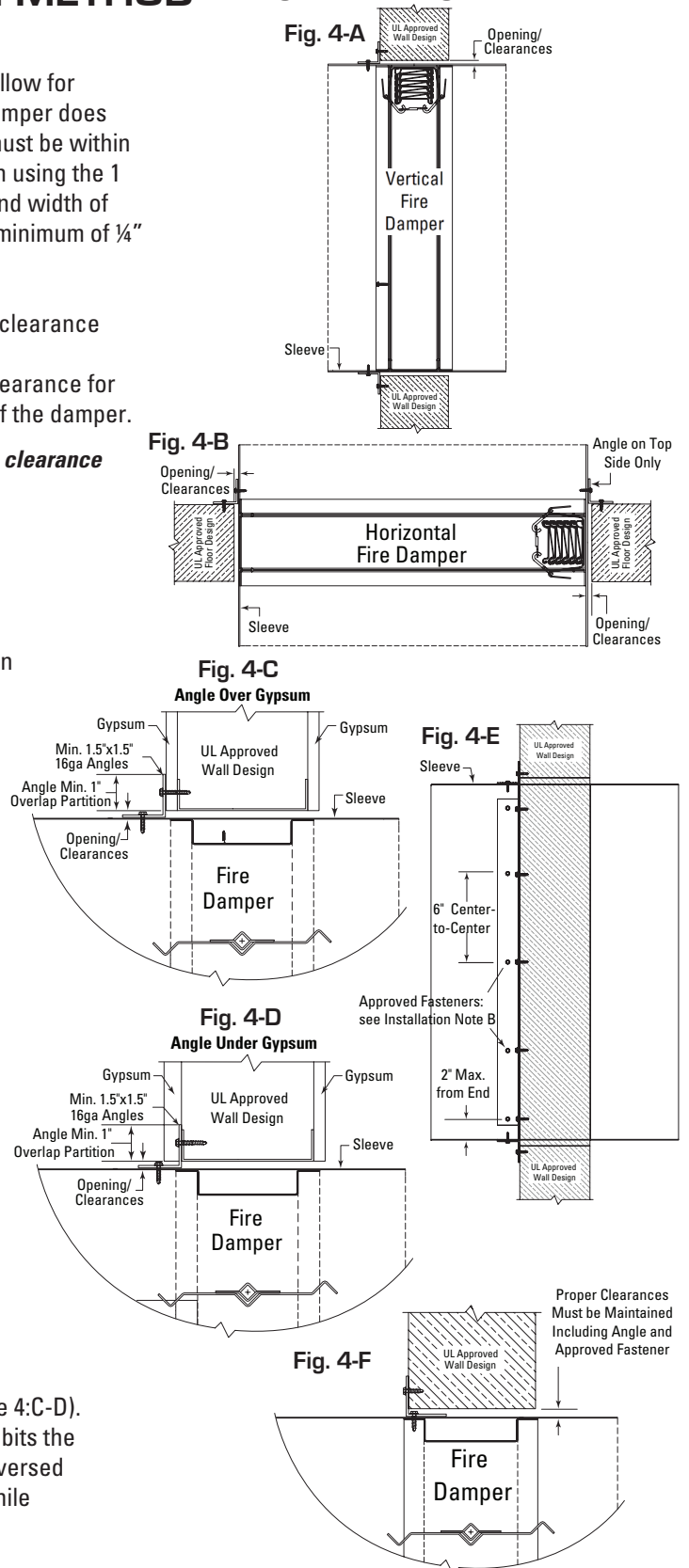

NO ANGLE (GRILLE MOUNT) INSTALLATION METHOD

Opening/Clearances:

The fire barrier opening shall be larger than the damper in order to allow for thermal expansion and ease of installation (see Figure 5:A-E). The damper does not have to be centered in wall or floor, only the blade closure line must be within the partition (see Figure 5:A-B). The opening in the fire rated partition using the no angle method shall be a minimum of ¼" (6mm) and maximum of ½" (13mm) larger than the sleeved damper assembly (see Figure 5:D-E).

Important Note: The clearances mentioned above are for the total clearance for the damper and does not necessarily need to be met on every side of the damper.

No materials (i.e. Fire Stop, Mineral Wool, etc.) are to be placed in this clearance between the damper sleeve and the wall/floor opening.

Guidelines:

The No Angle Method (Figure 5:A-E) is approved for the following:

- A. Masonry/concrete walls or floors and stud/gypsum walls
- B. 1 ½ Hour rated dampers
- C. Vertical (see Figure 5-A) or horizontal (see Figure 5-B) orientation (flange on top side only)
- D. The maximum size allowed for this method is 42" (1067mm) wide by 48" (1219mm) high up to the maximum multiple section UL approved damper size (see Underwriter's Laboratories Listings for maximum assembly sizes)

Installation:

1. Minimum of ¾" (19mm) flange on one end of the sleeve (see Figure 5-C).
2. The damper assembly shall be placed in the opening so that the flange rests flush up against the partition (see Figure 5:A-B).
3. The sleeve is to be fastened to the partition (see Figure 5:A-C) on 6" (152mm) centers with no more than 2" (51mm) on each end and a minimum of 2 fasteners per side/leg using #10 (M5) self-tapping concrete anchors or concrete screws engaging the fire partition a minimum of 1 ½" (38mm) for masonry/concrete partitions or #10 (M5) screws long enough to penetrate the J-Runners and E-Stud by a minimum of 3/8" (10mm) for stud/gypsum partitions.
4. In a steel stud application, the sleeve flange may be placed in front of or behind the drywall attaching directly to the metal studs (see Figure 5:D-E).

Figure 5: No Angle Installation

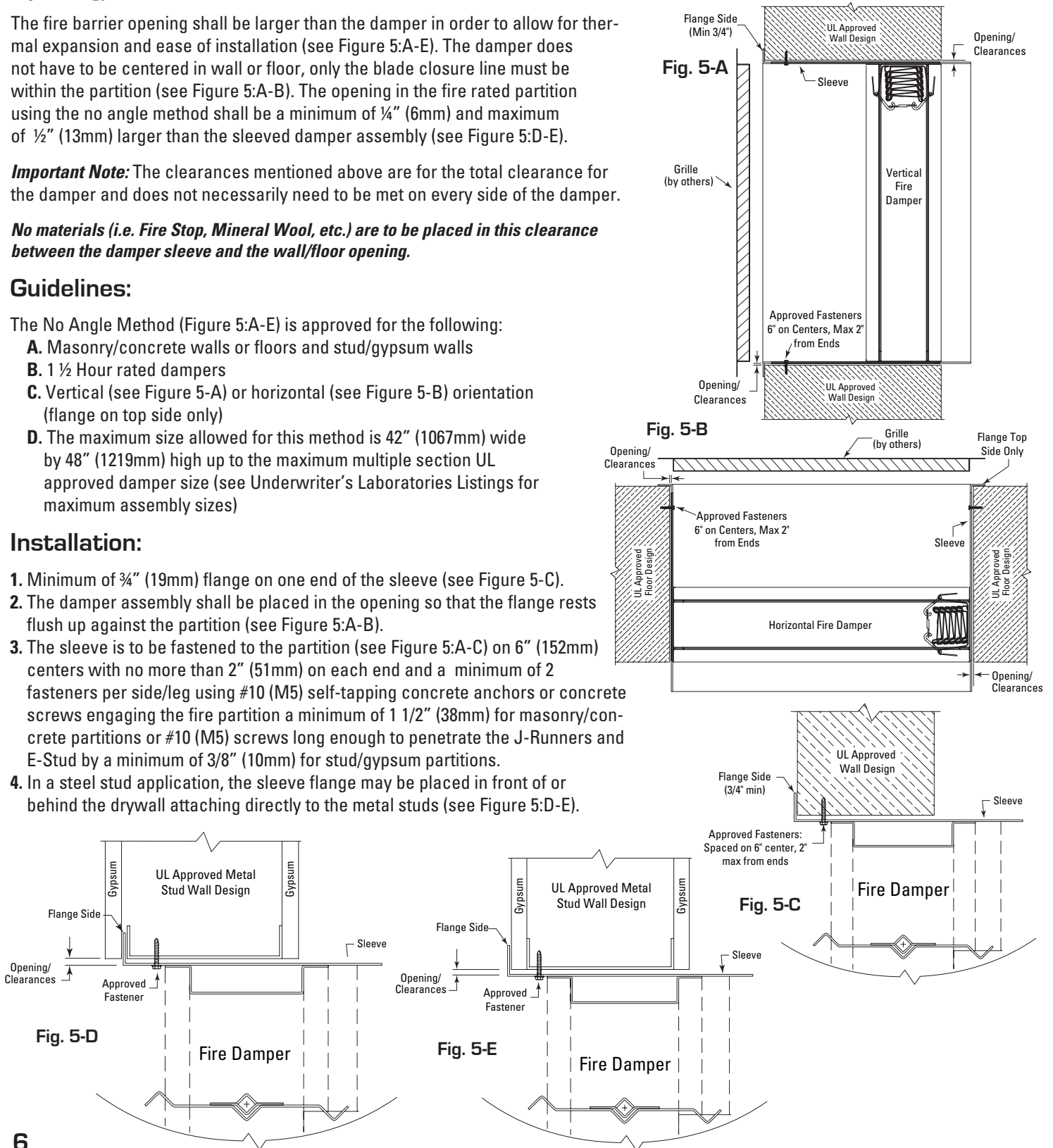

ACTUATOR CONNECTIONS (if applicable):

Electrical or pneumatic connections to damper actuators should be made in accordance with wiring and piping diagrams developed in compliance with applicable codes, ordinances and regulations. Be sure to check actuator for proper voltage and current draw. Tampering with the actuator's installation or connecting the actuator to an improper voltage and current may void the warranty.

DAMPER OPERATION, TESTING & MAINTENANCE

The procedures discussed here are intended to insure that nothing interferes with a damper's proper operation and to identify and eliminate a number of potential situations that could occur and interfere with said operation.

Fire Damper Operation:

All CVS fire dampers are operated at the factory, however pre-installation testing of its operation can be completed by bending the straps that hold the fusible link and temporarily removing the fusible link. Place the damper in its intended installation orientation (vertical or horizontal) and allow the curtain-style blade to close.

WARNING: During any operating, inspection or testing of fusible link and spring operated dampers, CVS recommends the following:

1. Caution is advised when a fusible link is suddenly released. Gravity or spring operated dampers may slam closed causing an abrupt interruption of airflow. As this could cause damage to ductwork, consideration should be given to conducting these tests without system airflow.
2. When removing the fusible link to check damper operation, be sure to keep fingers, hands and any other body parts out of the blade travel path to prevent injury.
3. Check closure springs. If defective, contact damper manufacturer for replacement procedures.

Fire Damper Testing:

All fire dampers and their fusible links or actuators shall be visually inspected and cycled at specific time intervals in accordance with the local building codes or the latest editions of NFPA 90A, 92A, local codes and UL 864. Also refer to the actuator manufacturer's recommendations if applicable.

IMPORTANT NOTE: If the fire damper has actuators and a thermostat installed on the damper, **do not apply a heat gun, flame or any heat producing device directly to the thermostat.** Simply disconnecting the power to the actuator(s) shall be sufficient for testing procedures.

Fire Damper Maintenance:

Fire Life-Safety related dampers that are properly applied, equipped with the appropriate UL labels, appropriately installed, and demonstrated to function as intended through a building commissioning process should require no specific preventive maintenance. However, CVS recommends that obstructions, dirt build up, and any rust or corrosion be removed using mild solvents or detergents. No lubrication is required, however if it is desired, damper tracks and blade hinges may be lubricated using a dry lubricant.

Never use a petroleum based lubricant as it will attract dust and eventually impede a damper's operation.

Message from CVS:

This installation, operation and maintenance instruction document has been reviewed and approved by the Underwriter's Laboratories.

As a part of CVS's continuous improvement program, CVS reserves the right to make further improvements or changes without notice.